

Perfect solution to all problems

Tips, Tricks, General Knowledge, Current Affairs, Latest Sample,  
Previous Year, Practice Papers with solutions.

## CBSE 10th Science 2017 Unsolved Paper Summative Assessment – I

Click Button Below To Buy Solution

BUY NOW WITH PayUmoney

**Only ₹ 25**

OR

Call us on **9557655662** for *Paytm* or *UPI / NEFT* payment

### Note

This pdf file is downloaded from [www.4ono.com](http://www.4ono.com). Editing the content or publicizing this on any blog or website without the written permission of [Rewire Media](http://www.4ono.com) is punishable, the suffering will be decided under DMCA

# CBSE 10th Science 2017 Unsolved Paper

## Summative Assessment – I

TIME - 3HR. | QUESTIONS – 42

THE MARKS ARE MENTIONED ON EACH QUESTION

---

### SECTION - A

**Q.1. What happens when  $ZnCO_3$  is heated in the absence of air? Give the relevant equation. 1mark**

**Q.2. Which gas is usually liberated when an acid reacts with a metal? 1mark**

**Q.3. Thermal power plants are setup near coal or oil fields. Give reason. 1mark**

**Q.4. Why do we use copper and Aluminium wire for transmission of electric current ?Why not iron? 2marks**

**Q.5. Write chemical equations for the reactions taking place when 2marks**

(i) zinc sulphide is heated in air

(ii) calcination of zinc carbonate is done.

**Q.6. Write observation with reaction for the following : Granulated zinc reacts with dil. sulphuric acid. 2marks**

**Q.7. “Respiration is an exothermic reaction.” Justify this statement giving the chemical equation for the reaction involved. 2marks**

**Q.8. The color of copper sulphate solution changes when an iron nail is dipped in it. State the giving chemical equation for the reaction involved. Write the name of reaction involved. 3marks**

**Q.9. Which is the internal energy reserve in plants? Do the animals have the same energy reserve ? Justify your answer. 3marks**

**Q.10. Differentiate between renewable and non-renewable sources of energy with one example for each. 3marks**

**Q.11. Resistances of three resistors are given as  $R_1 = 10 \Omega$ ,  $R_2 = 20 \Omega$  and  $R_3 = 30 \Omega$ . Calculate the effective resistance when they are connected in series. Also calculate the current flowing when the combination is connected to a 6V battery 3marks**

**Q.12. A student performs an experiment to study the magnetic effect of current around a current carrying straight conductor with the help of a magnetic compass. He reports that? 3marks**

**(i) the degree of deflection of the magnetic compass increases when the compass is moved away from the conductor.**

**(ii) the degree of deflection of the magnetic compass increases when the current through the conductor is increased.**

**Which of the above observations of the student appears to be wrong and why ?**

**Q.13. How would the reading of voltmeter (V) change if it is connected between C and D ? Justify your answer. 3marks**

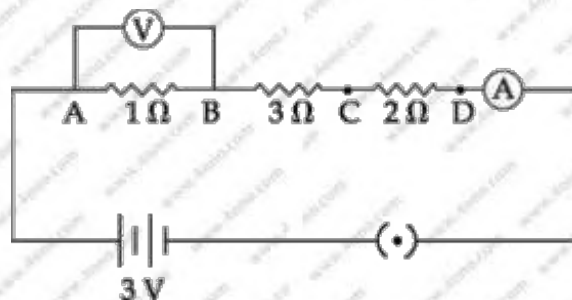

**Q.14. (a) Identify the substance oxidized, substance reduced, oxidizing agent and reducing agent in the following reaction:  $\text{ZnO} + \text{C} \rightarrow \text{Zn} + \text{CO}$**

**(b) Packets of potato chips are flushed with nitrogen gas, why? 3marks**

**Q.15. A blue colour salt becomes white on heating. Give reason for the above observation. What happens when we add water to the salt which is obtained after heating? Also write its formula. 3marks**

**Q.16. (a) How does baking soda help to make cakes and bread soft and spongy?**

**(b) List the raw materials used for the preparation of baking soda.**

**(c) Write chemical equation for its preparation. 3marks**

**Q.17. (a) Which hormone is responsible for the changes noticed in males at puberty?**

**(b) Deficiency of which hormone leads to dwarfism.**

**(c) Name the hormone which is injected to a diabetic patient. 3marks**

**Q.18. (a) What is reflex arc?**

**(b) How do muscle cells move? 3marks**

**Q.19. Draw a neat diagram of a biogas plant and label 3marks**

- (i) inlet of slurry
- (ii) digester
- (iii) gas outlet.

**Q.20. (a) A student performs an experiment with 4 cells and a resistance wire and an ammeter in series and observes that when the number of cells in the circuit is decreased, the value of current through the wire also decreases. Name the law that is involved in the experiment and write its mathematical form. V–I graph for two resistors  $R_1$ ,  $R_2$  and their series combination are shown in the figure below. Which graph represents the series combination of the other two? Give reason.**

**(b) Write difference between ammeter and voltmeter. 5marks**

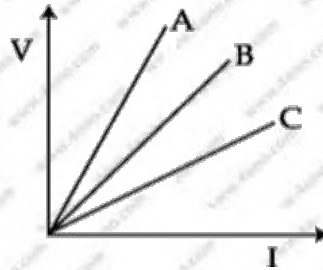

OR

**For the circuit shown in the diagram calculate.**

- (a) The total effective resistance of the circuit
- (b) the total current in the circuit
- (c) The value of current through  $20\Omega$  resistor.

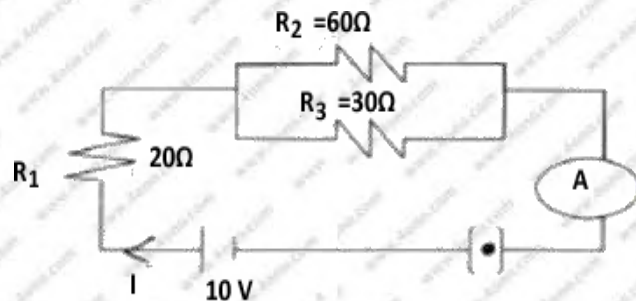

**Q.21. (a) Name the metal which is low in activity series and exists as liquid at room temperature.**

**(b) Write the name and formula of its ore.**

**(c) How is the metal extracted from this ore ?**

**(d) Write the chemical equation for the reaction involved. *5marks***

**OR**

**(i) What causes rusting of iron ? Design an activity to show the conditions needed for iron nails to rust.**

**(ii) Why do we paint iron articles ?**

**Q.22. (a) Draw a neat diagram of excretory system of human beings and label the following : *5marks***

**(i) Kidney**

**(ii) Ureter**

**(iii) Urinary Bladder**

**(iv) Urethra**

**(b) How is urine produced.**

**(c) Name two excretory products other than  $O_2$  and  $CO_2$  in plants.**

**OR**

**(a) Draw diagram to show the nutrition in amoeba and label the part used for this purpose. Mention any other purpose served by this part other than nutrition.**

**(b) Name the glands associated with digestion of starch in human digestive tract and mention their role.**

**(c) (a) How is required pH maintained in the stomach and small intestine**

**Q.23. (a) A coil of insulated copper wire is connected to a galvanometer. What will happen if a bar magnet is: 5marks**

- (i) Pushed into the coil with its north pole entering first?**
  - (ii) Withdrawn from inside the coil?**
  - (iii) Held stationary inside the coil?**
- (b) Name the above phenomenon and mention the name of the scientist who discovered it. State the law that relates the direction of current in the coil with the direction of motion of the magnet.**

**OR**

**Consider a circular loop of wire lying in the plane of the paper. Let the current pass through the loop clockwise. With the help of a diagram explain how the direction of the magnetic field can be determined inside and outside the loop.**

- (a) Name the law used to find the direction of magnetic field.**
- (b) Draw a diagram to represent a uniform magnetic field in a given region.**
- (c) List two properties of magnetic field lines.**

**Q.24. (a) Name the enzyme present in saliva. Why is it important? 5marks**

- (b) What is emulsification?**
- (c) Name the substance that is oxidized in the body during respiration.**
- (d) Why are lungs divided into very small sac-like structures?**

**OR**

- (a) Draw a neat diagram of human respiratory system and label the parts and label 9 parts in it.**
- (b) What are the end products of digestion of fat and protein in human beings?**

SEACTION - B

**Q.25. A student was observing a pH chart. He observed that the two colours at the extreme ends of the pH chart are: *1mark***

- (a) Red and green
- (b) red and blue
- (c) green and blue
- (d) orange and green pH

**Q.26. When a drop of an unknown solution X is placed on a strip of pH paper, a deep blue colour is produced. This solution should be – *1mark***

- (a) NaOH
- (b) Lemon luice
- (c) Water
- (d) HCl

**Q.27. On adding dilute hydrochloric acid to granulated zinc placed in a test tube, a student would observe that: *1mark***

- (a) The surface of the metal turns shining.
- (b) the reaction mixture turns milky.
- (c) The reaction mixture gives odor of chlorine.
- (d) A colorless and odorless gas evolves with bubbles.

**Q.28. When sodium sulphate solution and barium chloride solution are mixed together, the colour of precipitate formed is: *1mark***

- (a) Yellow
- (b) Green
- (c) White
- (d) Red



**Q.29. While doing an experiment a student observed that the blue colour of the aqueous copper sulphate solution was changed to pale green by immersing a metal rod in it. The metal of the rod used by the student is: *1mark***

- (a) iron
- (b) zinc
- (c) silver
- (d) aluminium

**Q.30. Which of the following is the correct method to connect the ammeter and voltmeter with resistance in the circuit to verify the Ohm's law? *1mark***

- (a) ammeter and the voltmeter in series
- (b) Ammeter in series and voltmeter in parallel
- (c) Ammeter but no voltmeter
- (d) Voltmeter and ammeter in parallel

**Q.31. In the experiment to study the dependence of current on potential difference across a resistor, a student obtained a graph as shown in the diagram. The value of resistance of the resistor is: *1mark***

- (a)  $0.1 \Omega$
- (b)  $1.0 \Omega$
- (c)  $10 \Omega$
- (d)  $100 \Omega$

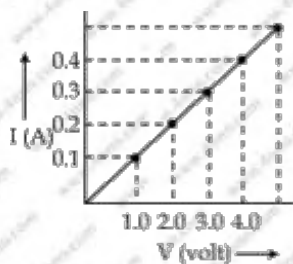

**Q.32. While studying relation between V and I it is suggested that ammeter should always be connected** *1mark*

- (a) parallel to conductor
- (b) Series in the circuit
- (c) Either in parallel or in series
- (d) Neither a nor b

**Q.33. A leaf is boiled in alcohol before using iodine for starch test in order to** *1mark*

- (a) Dissolve starch.
- (b) dissolve chlorophyll
- (c) softening the leave
- (d) to kill the enzymes

**Q.34. Study the two circuits circuit I and circuit II shown below. In circuit I, ammeter reads current  $I_1$  and voltmeter reads voltage  $V_1$ . In circuit II, ammeter reads current  $I_2$  and voltmeter reads voltage  $V_2$ . Which one of the following is the correct statement about the ammeter and voltmeter readings?** *1mark*

- (a)  $I_1 > I_2$ ;  $V_1 = V_2$
- (b)  $I_1 < I_2$ ;  $V_1 = V_2$
- (c)  $I_1 > I_2$ ;  $V_1 > V_2$
- (d)  $I_1 < I_2$ ;  $V_1 < V_2$

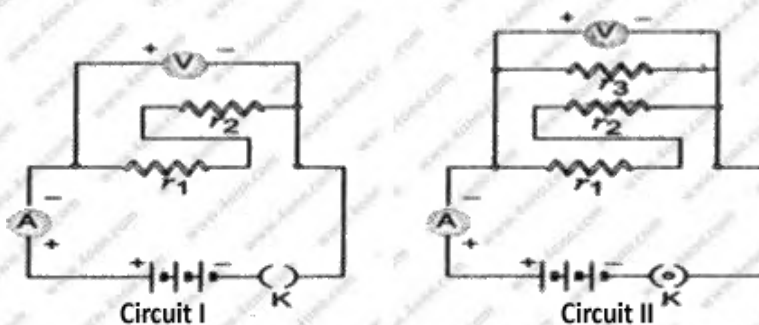

**Q.35. To make the plant free of starch, it is kept: *1mark***

- (a) in darkness for 72 hours.**
- (b) in a room, but with lights on at night only.**
- (c) Under the shade of a tree.**
- (d) covered with coloured polythene in a shady place.**

**Q.36. During the experiment to show that plants do photosynthesis, the destarched leaf is boiled in alcohol. Once boiling is completed *1mark***

- (a) alcohol remains colourless**
- (b) leaf remains greenish**
- (c) alcohol turns greenish and leaf becomes colourless**
- (d) no visible change occur**

**Q.37. While preparing a temporary stained mount of a leaf epidermal peel, the extra stain is removed by: *1mark***

- (a) washing with water**
- (b) washing with calcium chloride**
- (c) soaking with filter paper**
- (d) absorbing with cotton wool**

**Q.38. A student focused the leaf epidermal peel under a low power microscope, but he could not see all the parts. He should: *1mark***

- (a) use the coarse adjustment knob again to focus the slide**
- (b) use the fine adjustment knob to increase magnification**
- (c) focus under high power using coarse adjustment knob**
- (d) focus under high power using fine adjustment knob**

**Q.39.** After performing the experiment to show that germinating seeds give out carbon dioxide during respiration, students drew the following labelled diagrams. The correct labeled diagram is. *1mark*

- (a) A
- (b) B
- (c) C
- (d) D

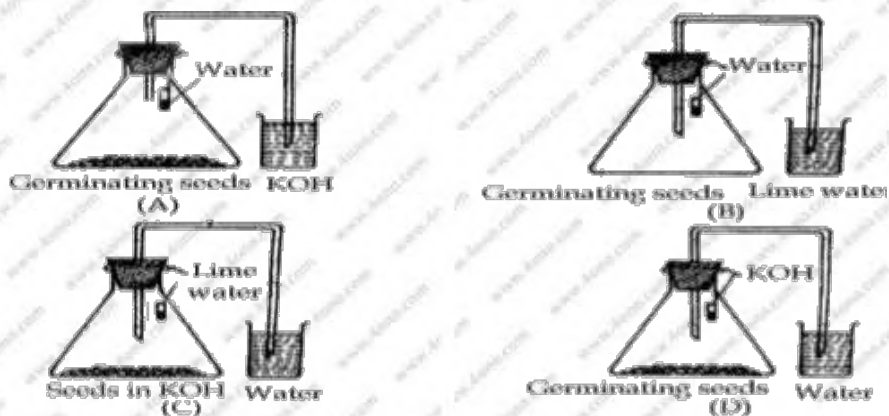

**Q.40.** Before setting up an experiment to show that seeds release  $\text{CO}_2$  during respiration, the seeds should be: *1mark*

- (a) Dried completely.
- (b) Boiled to make them soft.
- (c) Soaked in vinegar.
- (d) kept moist till they germinate.

**Q.41.** An iron nail is placed in solution of copper sulphate. The nail is taken out after 10 minutes. The nail will be found to be covered with. *1mark*

- (a) brown deposit
- (b) black deposit
- (c) white deposit
- (d) grey deposit

**Q.42. An ammeter has a range of (0-3) ampere and there are 30 division on its scale. What is its least count. *1mark***

- (a) 1.0 A
- (b) 0.5 A
- (c) 0.1 A
- (d) 0.01 A

**Click Button Below To Buy Solution**

**BUY NOW WITH PayUmoney**

**Only ₹ 25**

**OR**

**Call us on *9557655662* for *Paytm* or *UPI / NEFT* payment**

