



Perfect solution to all problems

Tips, Tricks, General Knowledge, Current Affairs, Latest Sample,
Previous Year, Practice Papers with solutions.

CBSE 10th Mathematics 2016 Unsolved Paper All India

Buy solution: <http://www.4ono.com/cbse-10th-maths-solved-previous-year-papers/>

Note

This pdf file is downloaded from www.4ono.com. Editing the content or publicizing this on any blog or website without the written permission of [Rewire Media](#) is punishable, the suffering will be decided under DMCA

CBSE 10th Mathematics 2016 Solved Paper

All India

TIME - 3HR. | QUESTIONS - 31

THE MARKS ARE MENTIONED ON EACH QUESTION

SECTION - A

Q.1. In fig. 1, PQ is a tangent at a point C to a circle with centre O. If AB is a diameter and $\angle CAB = 30^\circ$, find $\angle PCA$. 1 mark

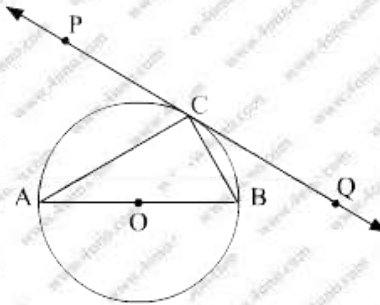

Q.2. For what value of k will $k + 9$, $2k - 1$ and $2k + 7$ are the consecutive terms of an A.P.? 1 mark

Q.3. A ladder, leaning against a wall, makes an angle of 60° with the horizontal. If the foot of the ladder is 2.5 m away from the wall, find the length of the ladder. .? 1 mark

Q.4 A card is drawn at random from a well shuffled pack of 52 playing cards. Find the probability of getting neither a red card nor a queen. 1 mark

SECTION - B

Q.5. If -5 is a root of the quadratic equation $2x^2 + px - 15 = 0$ and the quadratic equation $p(x^2 + x) + k = 0$ has equal roots, find the value of k . 2 marks

Q.6. Let P and Q be the points of trisection of the line segment joining the points A(2, -2) and B(-7, 4) such that P is nearer to A. Find the coordinates of P and Q. *2 marks*

Q.7. In Figure, a quadrilateral ABCD is drawn to circumscribe a circle with centre O in such a way that the sides AB, BC, CD and DA touch the circle at the points P, Q, R and S respectively. Prove that $AB + CD = BC + DA$. *2 marks*

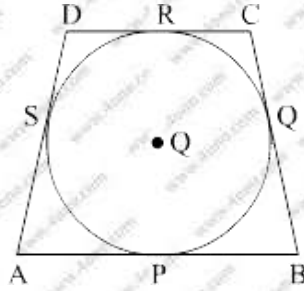

Q.8. Prove that the points (3, 0), (6, 4) and (-1, 3) are the vertices of a right angled isosceles triangle. *2 marks*

Q.9. The 4th term of an A.P. is zero. Prove that the 25th term of the A.P. is three times its 11th term. *2 marks*

Q.10. In Fig. 3, from an external point P, two tangents PT and PS are drawn to a circle with centre O and radius r . *2 marks*
If $OP = 2r$, show that $\angle OTS = \angle OST = 30^\circ$.

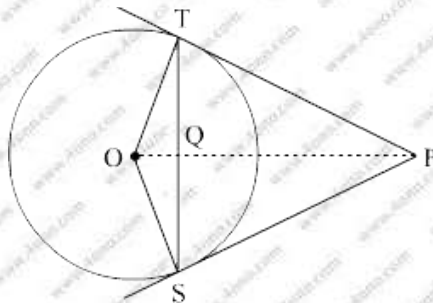

SECTION - C

Q.11. In fig. 4, O is the centre of a circle such that diameter AB = 13 cm and AC = 12 cm. BC is joined. Find the area of the shaded region. (Take $\pi = 3.14$) 3 marks

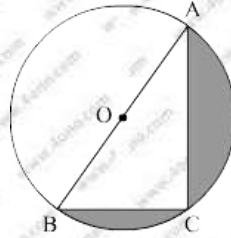

Q.12. In the figure, a tent is in the shape of a cylinder surmounted by a conical top of same diameter. If the height and diameter of cylindrical part are 2.1 m and 3 m, respectively, and the slant height of conical part is 2.8 m, find the cost of canvas needed to make the tent if the canvas is available at the rate of Rs 500/sq. metre. (Use $\pi = \frac{22}{7}$). 3 marks

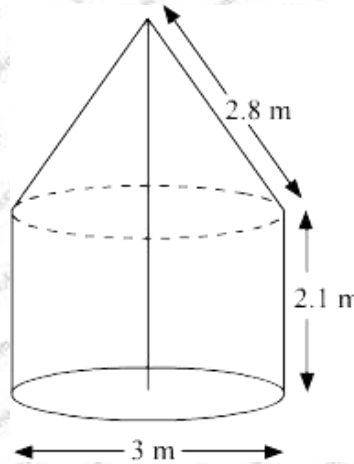

Q.13. If the point P(x, y) is equidistant from the points A(a + b, b - a) and B(a - b, a + b). Prove that bx = ay. 3 marks

Q.14. In fig. 6, find the area of the shaded region, enclosed between two concentric circles of radii 7 cm and 14 cm, where $\angle AOC = 40^\circ$. (Use $\pi = \frac{22}{7}$). 3 marks

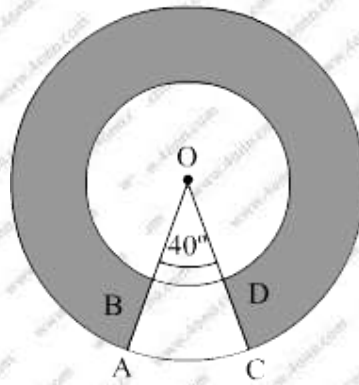

Q.15. If the ratio of the sum of first n terms of two A.P's is $(7n + 1) : (4n + 27)$, find the of their m^{th} terms. *3 marks*

Q.16. Solve for x : $\frac{1}{(x-1)(x-2)} + \frac{1}{(x-2)(x-3)} = \frac{2}{3}$, $x \neq 1, 2, 3$ *3 marks*

Q.17. A conical vessel, with base radius 5 cm and height 24 cm, is full of water. This water is emptied into a cylindrical vessel of base radius 10 cm. Find the height to which the water will rise in the cylindrical vessel. (*Use $\pi = \frac{22}{7}$*). *3 marks*

Q.18. A sphere of diameter 12 cm, is dropped in a right circular cylindrical vessel, partly filled with water. If the sphere is completely submerged in water, the water level in the cylindrical vessel rises by $3\frac{5}{9}$ cm. Find the diameter of the cylindrical vessel. *3 marks*

Q.19. A man standing on the deck of a ship, which is 10 m above water level, observes the angle of elevation of the top of a hill as 60° and the angle of depression of the base of hill as 30° . Find the distance of the hill from the ship and the height of the hill. *3 marks*

- Q.20. Three different coins are tossed together. Find the probability of getting**
 (i) exactly two heads (ii) at least two heads (iii) at least two tails. *3 marks*

SECTION -D

- Q.21. Due to heavy floods in a state, thousands were rendered homeless. 50 schools collectively offered to the state government to provide place and the canvas for 1500 tents to be fixed by the government and decided to share the whole expenditure equally. The lower part of each tent is cylindrical of base radius 2.8 m and height 3.5 m, with conical upper part of same base radius but of height 2.1 m. If the canvas used to make the tents costs Rs 120 per sq.m, find the amount shared by each school to set up the tents. What value is generated by the above problem? ($Use \pi = \frac{22}{7}$). *4 marks***

- Q.22. Prove that the lengths of the tangents drawn from an external point to a circle are equal. *4 marks***

- Q.23. Draw a circle of radius 4 cm. Draw two tangents to the circle inclined at an angle of 60° to each other. *4 marks***

- Q.24. In the figure, two equal circles, with centres O and O', touch each other at X. OO' produced meets the circle with centre O' at A. AC is tangent to the circle with centre O, at the point C. O'D is perpendicular to AC. Find the value of $\frac{DO'}{CO}$. *4 marks***

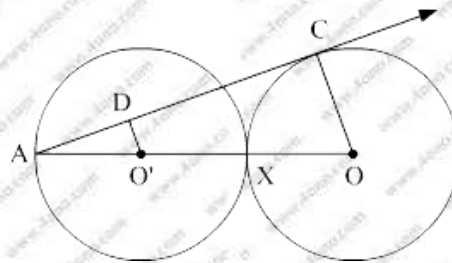

Q.25. Solve for x : $\frac{1}{x+1} + \frac{2}{x+2} = \frac{4}{x+4}$, $x \neq -1, -2, -4$ 4 marks

Q.26. The angle of elevation of the top Q of a vertical tower PQ from a point X on the ground is 60° . From a point Y, 40 m vertically above X, the angle of elevation of the top Q of tower is 45° . Find the height of the tower PQ and the distance PX. (Use $\sqrt{3} = 1.73$) 4 marks

Q.27. The houses in a row are numbered consecutively from 1 to 49. Show that there exists a value of X such that sum of numbers of houses proceeding the house numbered X is equal to sum of the numbers of houses following X. 4 marks

Q.28. In fig. 8, the vertices of $\triangle ABC$ are A(4, 6), B(1, 5) and C(7, 2). A line-segment DE is drawn to intersect the sides AB and AC at D and E, respectively, such that $\frac{AD}{AB} = \frac{AE}{AC} = \frac{1}{3}$. Calculate the area of $\triangle ADE$ and compare it with area of $\triangle ABC$. 4 marks

Q.29. A number x is selected at random from the numbers 1, 2, 3 and 4. Another number y is selected at random from the numbers 1, 4, 9 and 16. Find the probability that product of x and y is less than 16. 4 marks

30. In Figure, is shown a sector OAP of a circle with centre O, containing $\angle\theta$. AB is perpendicular the radius OA and meets OP produced at B. Prove that the perimeter of shaded region is $r[\tan\theta + \sec\theta + \frac{\pi\theta}{180} - 1]$. 4 marks

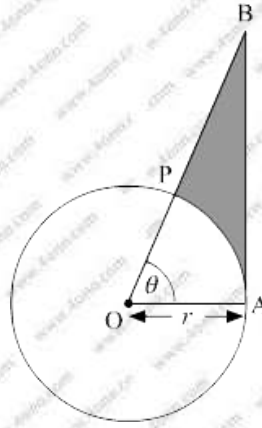

Q.31. A motor boat whose speed is 24 km/h in still water takes 1 hour more to go 32 km upstream than to return downstream to the same spot. Find the speed of the stream. *4 marks*



Buy solution: <http://www.4ono.com/cbse-10th-maths-solved-previous-year-papers/>