

CBSE Annual Examination Question Paper 2013

PHYSICS (THEORY)

Time allowed: 3 hours]

[Maximum marks: 70

General Instructions:

- (i) All questions are compulsory.
- (ii) There are **29** questions in total. Question Nos. **1** to **8** are very short answer type questions and carry **one** marks each.
- (iii) Question Nos. **9** to **16** carry **two** marks each, Question Nos. **17** to **25** carry **three** marks each and Question Nos. **27** to **29** carry **five** marks each.
- (iv) There is no overall choice. However, an internal choice has been provided in **one** question of **two** marks, **one** question of **three** marks and all **three** questions of **five** marks each. You have to attempt only **one** of the choices in such questions.
- (v) Question No. **26** is value based question carries **four** marks.
- (vi) Use of calculators is not permitted. However, you may use log tables if necessary.
- (vii) You may use the following values of physical constants wherever necessary:

$$c = 3 \times 10^8 \text{ m/s}$$

$$h = 6.63 \times 10^{-34} \text{ Js}$$

$$e = 1.6 \times 10^{-19} \text{ C}$$

$$\mu_0 = 4\pi \times 10^{-7} \text{ TmA}^{-1}$$

$$\frac{1}{4\pi\epsilon_0} = 9 \times 10^9 \text{ Nm}^2\text{C}^{-2}$$

$$m_e = 9.1 \times 10^{-31} \text{ kg}$$

$$\text{Mass of the Neutron} = 1.675 \times 10^{-27} \text{ kg}$$

$$\text{Mass of the Proton} = 1.673 \times 10^{-27} \text{ kg}$$

1. What are permanent magnets? Give one example.
2. What is the geometrical shape of equipotential surfaces due to a single isolated charge?
3. Which of the following waves can be polarized (i) Heat waves (ii) Sound waves?
4. A capacitor has been charged by a dc source. What are the magnitudes of conduction and displacement currents, when it is fully charged?
5. Write the relationship between angle of incidence 'i', prism 'A' and angle of minimum deviation for a triangular prism.

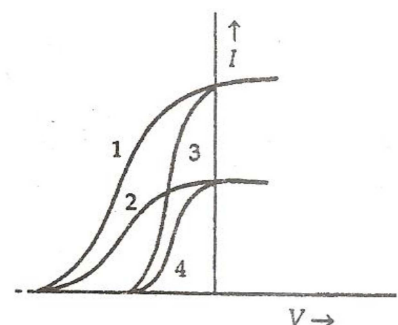

6. The given graph shows the variation of photo-electric current (I) versus applied voltage (V) for two different photosensitive materials and for two different intensities of the incident radiation. Identify the pairs of curves that correspond to different materials but same intensity of incident radiation.
7. A 10 V battery of negligible internal resistance is connected across a 200 V battery and a resistance of 38Ω as shown in the figure. Find the value of the current in circuit.

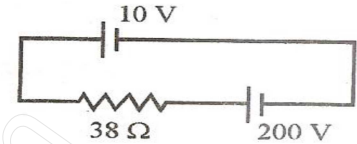

8. The emf of a cell is always greater than its terminal voltage. Why? Give reason.
9. (a) Write the necessary conditions for the phenomenon of total internal reflections to occur.
(b) Write the relation between the refractive index and critical angle for a given pair of optical media.
10. State Lenz's Law. A metallic rod held horizontally along east-west direction, is allowed to fall under gravity. Will there be an emf induced at its ends? Justify your answer.
11. A convex lens of focal length 25 cm is placed coaxially in contact with a concave lens of focal length 20 cm. Determine the power of the combination. Will the system be converging or diverging in nature?
12. An ammeter of resistance 0.80Ω can measure current upto 1.0A.
(i) What must be the value of shunt resistance to enable the ammeter to measure current upto 5.0A?
(ii) What is the combined resistance of the ammeter and the shunt?

13. In the given circuit diagram, a voltmeter 'V' is connected across a lamp 'L'. How would (i) the brightness of the lamp and (ii) voltmeter reading 'V' be affected, if the value of resistance 'R' is decreased? Justify your answer.

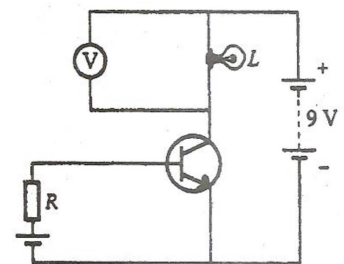

14. (a) An em wave is travelling in a medium with a velocity $\vec{v} = v\hat{i}$. Draw a sketch showing the propagation of the em wave, indicating the direction of the oscillating electric and magnetic fields.
- (b) How are the magnitudes of the electric and magnetic fields related to the velocity of the em wave?
15. Block diagram of a receiver is shown in the figure:

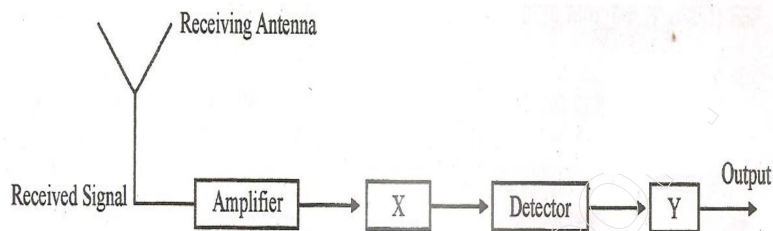

- (a) Identify 'X' and 'Y'.
- (b) Write their functions.
16. Explain, with the help of a circuit diagram, the working of a photo-diode. Write briefly how it is used to detect the optical signals. **OR**
Mention the important considerations required while fabricating a p-n junction diode to be used as a Light Emitting Diode (LED). What should be the order of band gap of an LED if it is required to emit light in the visible range?
17. Write three important factors which justify the need of modulating a message signal. Show diagrammatically how an amplitude modulate wave is obtained when a modulating signal is superimposed on a carrier wave.
18. A capacitor of unknown capacitance is connected across a battery of V volts. The charge stored in it is $360\mu C$. When potential across the capacitor is reduced by $120 V$, the charge stored in it becomes $120\mu C$.
- Calculate:
- (i) The potential V and the unknown capacitance C .
- (ii) What will be the charge stored in the capacitor, if the voltage applied had increased by $120V$?

OR

A hollow cylindrical box of length 1m and area of cross-section 25cm^2 is placed in a three dimensional coordinate system as shown in the figure. The electric field in the region is given by $\vec{E} = 50x\hat{i}$, where E is in NC^{-1} and x is in metres. Find:

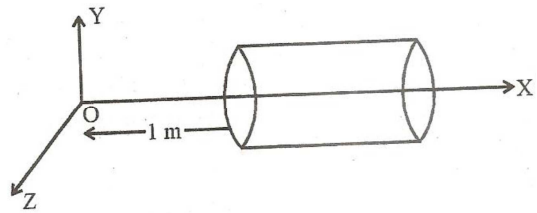

- (i) Net flux through the cylinder.
 (ii) Charge enclosed by the cylinder.
19. (a) In a typical nuclear reaction, e.g. ${}^2_1\text{H} + {}^2_1\text{H} \rightarrow {}^3_2\text{He} + n + 3.27\text{MeV}$,
 Although number of nucleons is conserved, yet energy is released. How? Explain.
 (b) Show that nuclear density in a given nucleus is independent of mass number A.
20. (a) Why photoelectric effect cannot be explained on the basis of wave nature of light?
 Give reasons.
 (b) write the basis features of photon picture of electromagnetic radiation on which Einstein's photoelectric equation is based.
21. A metallic rod of length 'l' is rotated with a frequency ν with one end hinged at the centre and the other end at the circumference of a circular metallic ring of radius r, about an axis passing through the centre and perpendicular to the plane of the ring. A constant uniform magnetic field B parallel to the axis is present everywhere. Using Lorentz force, explain how emf is induced between the centre and the metallic ring and hence obtain the expression for it.

22. Output characteristics of an n-p-n transistor in CE configuration is shown in the figure. Determine:

- (a) Dynamic output resistance
 (b) DC current gain and
 (c) AC current gain at an operating point $V_{CE}=10\text{V}$, when $I_B=30\mu\text{A}$.

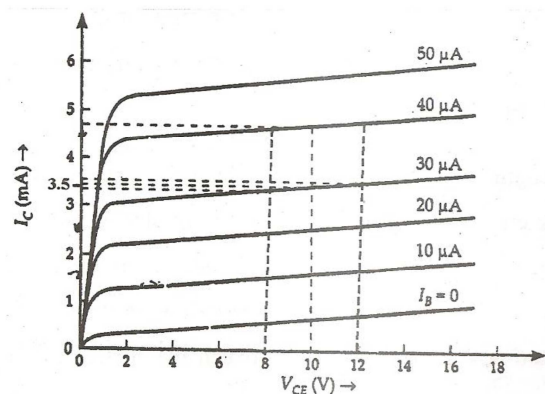

-
23. Using Bohr's postulates, obtain the expression for the total energy of the electron in the stationary states of the hydrogen atom. Hence draw the energy level diagram showing how the line spectra corresponding to Balmer series occur due to transition between energy levels.
24. (a) In what way is diffraction from each slit related to the interference pattern in a double slit experiment?
(b) Two wavelength of sodium light 590 nm and 596 nm are used, in turn, to study the diffraction taking place at a single slit of aperture 2×10^{-4} m. The distance between the slit and the screen is 1.5.m. Calculate the separation between the positions of the first maxima of the diffraction pattern obtained in the two cases.
25. In a series LCR circuit connected to an ac source of variable frequency and voltage $v = v_m \sin \omega t$, draw a plot showing the variation of current (I) with angular frequency (ω) for two different values of resistance R_1 and R_2 ($R_1 > R_2$). Write the condition under which the phenomenon of resonance occurs. For which values of the resistance out of the two curves, a sharper resonance is produced? Define Q-factor of the circuit and give its significance.
26. While travelling back to his residence in the car, Dr. Pathak was caught up in a thunderstorm. It became very dark. He stopped driving the car and waited for thunderstorm to stop. Suddenly he noticed a child walking alone on the road. He asked the boy at his residence. The boy insisted that Dr. Pathak should meet his parents. The parents expressed their gratitude to Dr. Pathak for his concern for safety of the child.

Answer the following questions based on the above information:

- (a) Why is it safer to sit inside a car during a thunderstorm?
(b) Which two values are displayed by Dr. Pathak in his actions?
(c) Which values are reflected in parents' response to Dr. Pathak?
(d) Give an example of a similar action on your part in the past from everyday life.
27. (a) Draw a ray diagram showing the image formation by a compound microscope. Hence obtain expression for total magnification when the image is formed at infinity.
-

(b) Distinguish between myopia and hypermetropia. Show diagrammatically how these defects can be corrected.

OR

(a) State Huygen's principle. Using this principle draw a diagram to show how a plane wave front incident at the interface of the two media gets refracted when it propagates from a rarer to a denser medium. Hence verify Snell's law of refraction.

(b) When monochromatic light travels from a rarer to a denser medium, explain the following, giving reasons:

(i) Is the frequency of reflected and refracted light same as the frequency of incident light?

(ii) Does the decrease in speed imply a reduction in the energy carried by light wave?

28. (a) State the working principle of a potentiometer. With the help of the circuit diagram; explain how a potentiometer is used to compare the emf's of two primary cells. Obtain the required expression used for comparing the emf's.

(b) Write two possible causes for one sided deflection in a potentiometer experiment.

OR

(a) State Kirchhoff's rules for an electric network. Using Kirchhoff's rules, obtain the balance condition in terms of the resistances of four arms of Wheatstone bridge.

(b) In the meterbridge experimental set up, shown in the figure, the null point 'D' is obtained at a distance of 40 cm from end A of the meterbridge wire. If a resistance of $10\ \Omega$ is connected in series with R_1 , null point is obtained at $AD=60$ cm. Calculate the values of R_1 and R_2 .

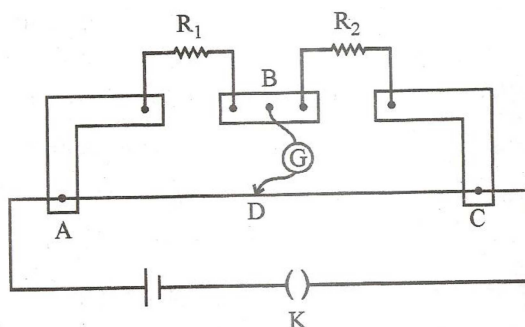

29. (a) Derive the expression for the torque on a rectangular current carrying loop suspended in a uniform magnetic field.

(b) A proton and a deuteron having equal momenta enter in a region of uniform magnetic field at right angle to the direction of the field. Depict their trajectories in the field.

OR

(a) A small compass needle of magnetic moment 'm' is free to turn about an axis perpendicular to the direction of uniform magnetic field 'B'. The moment of inertia of the needle about the axis is 'I'. The needle is slightly disturbed from its stable position and then released. Prove that it executes simple harmonic motion. Hence deduce the expression for its time period.

(b) A compass needle, free to turn in a vertical plane orients itself with its axis vertical at a certain place on the earth. Find out the values of (i) horizontal component of earth's magnetic field and (ii) angle of dip at the place.

For More Sample Papers Visit : www.4ono.com